

# icovia® Space Planner

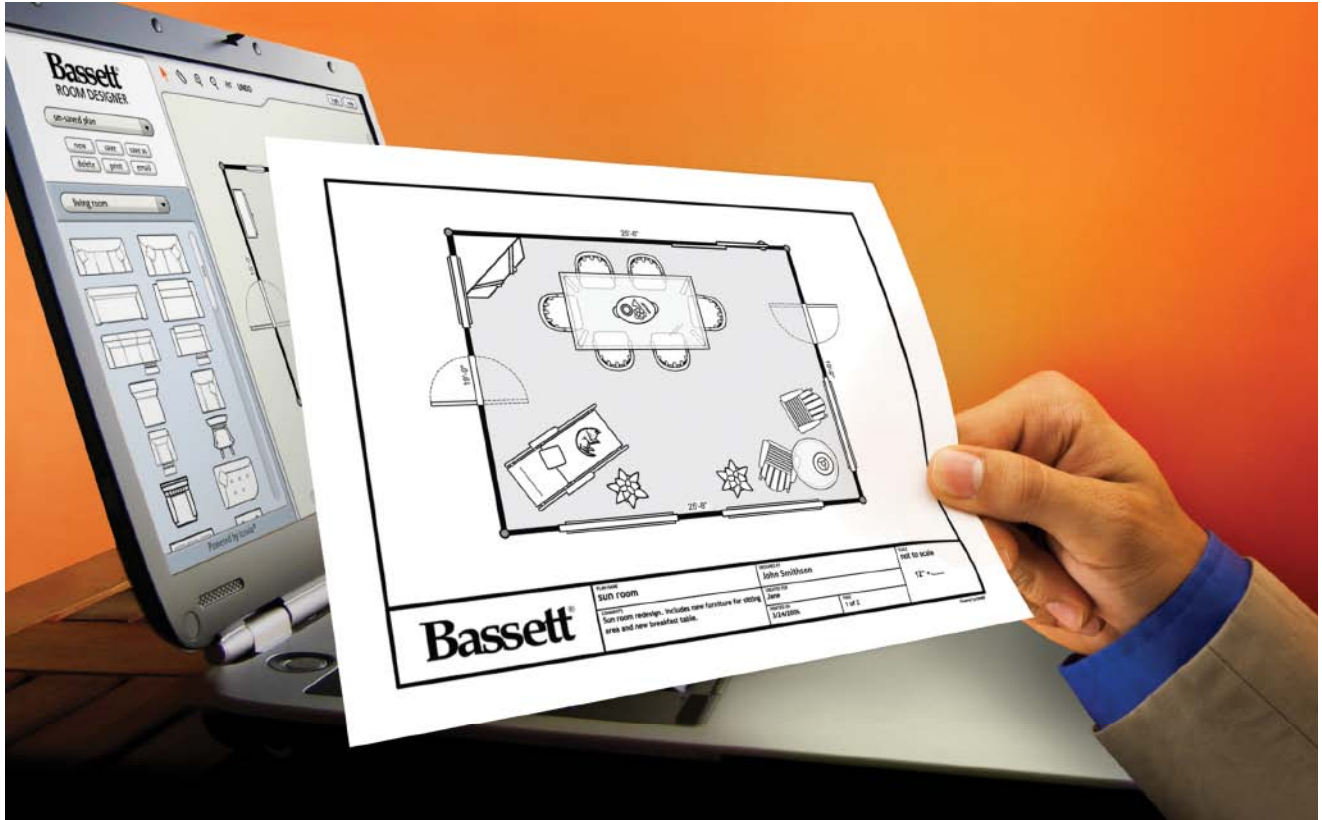

Icovia is a powerful sales and marketing tool for your furniture business and a versatile design tool for your customers.

Icovia launches from your website and store kiosks and is branded with your corporate identity.

**Over 140 retailers and manufacturers use Icovia Business Edition to generate leads and engage customers online.**

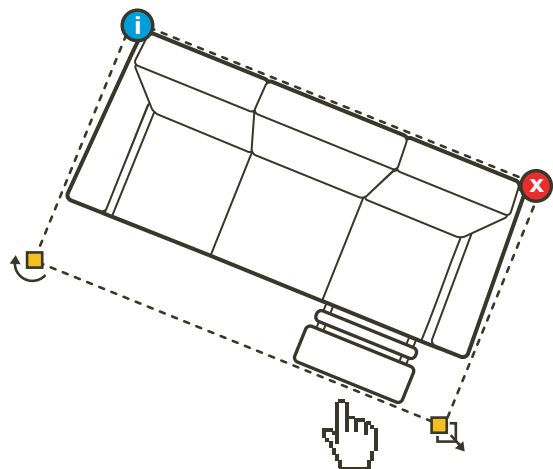

# icovia® Space Planner



- Links from your website or store kiosks
- Easy to use – No software to install
- Icovia generates over 100 new leads per month for most customers
- Icovia reduces no-fits and returns
- Integrates with your product catalog
- A top U.S. retailer estimates Icovia has increased sales by 2% (\$7 million)

Icovia helps you turn browsers into qualified leads and existing customers into repeat buyers.

Use the Icovia Reporting Tool to help you identify which products your customers are looking at and how they've arranged their rooms. These insights can help you market your products more effectively.

Report Name	Product Name	Email Address	Account Created	Last Plan Created
Andy	Andrew	andrew@icovia.com	2/27/2008 10:46:30 AM	2/27/2008 10:51:16 AM
Carla	Anderson	carla@icovia.com	6/18/2005 5:30:25 PM	5/6/2005 5:32:14 PM
Chris	Brown	chris@icovia.com	6/18/2005 5:14:47 AM	6/20/2005 5:21:34 AM
Christina	Anderson	christina@icovia.com	11/20/2005 10:30:28 AM	11/20/2005 10:31:10 AM
Edwina	Edwin	edwin@icovia.com	6/18/2005 10:20:13 AM	6/18/2005 10:20:13 AM
Diana	Diana	diana@icovia.com	3/17/2005 12:43:28 AM	3/17/2005 2:26:13 AM
Leah	Leah	leah@icovia.com	11/20/2005 10:30:28 AM	11/20/2005 10:30:28 AM
Heidi	Heidi	heidi@icovia.com	6/18/2005 1:02:20 PM	6/18/2005 1:02:20 PM
Tina	Tina	tina@icovia.com	3/21/2005 9:55:21 AM	3/21/2005 9:55:21 AM
Paul	Paul	paul@icovia.com	6/18/2005 10:31:24 AM	6/22/2005 11:18:02 PM
Andrea	Andrea	andrea@icovia.com	3/21/2005 12:44:24 PM	3/21/2005 12:44:24 PM
Wendy	Wendy	wendy@icovia.com	10/13/2005 10:34:33 AM	10/13/2005 10:34:33 AM
Christina	Christina	christina@icovia.com	5/12/2005 1:44:30 PM	5/12/2005 1:44:30 PM
Jane	Jane	jane@icovia.com	6/18/2005 10:30:28 AM	6/18/2005 10:30:28 AM
Wendy	Wendy	wendy@icovia.com	5/12/2005 1:44:30 PM	5/12/2005 1:44:30 PM
Paul	Paul	paul@icovia.com	6/18/2005 1:02:20 PM	6/20/2005 6:00:00 AM

- An online retailer saw a 1600% increase in the average order size as a direct result of Icovia

"[Icovia] was added six months ago and is paying huge dividends in increasing the percentage of shoppers who are converted into purchasers."

**Ken Kwit**  
President, FurnitureFind

"Salespeople love it because it helps them get the customer's attention and keep it through a process of planning a room."

**Joe Capilo**  
Director of Sales, Lane Tristate Stores



For more information visit us at [www.icovia.com/furniture](http://www.icovia.com/furniture) or call 603 206 6206.